

# M&J P250

Waste Pre-Shredders from M&J Recycling

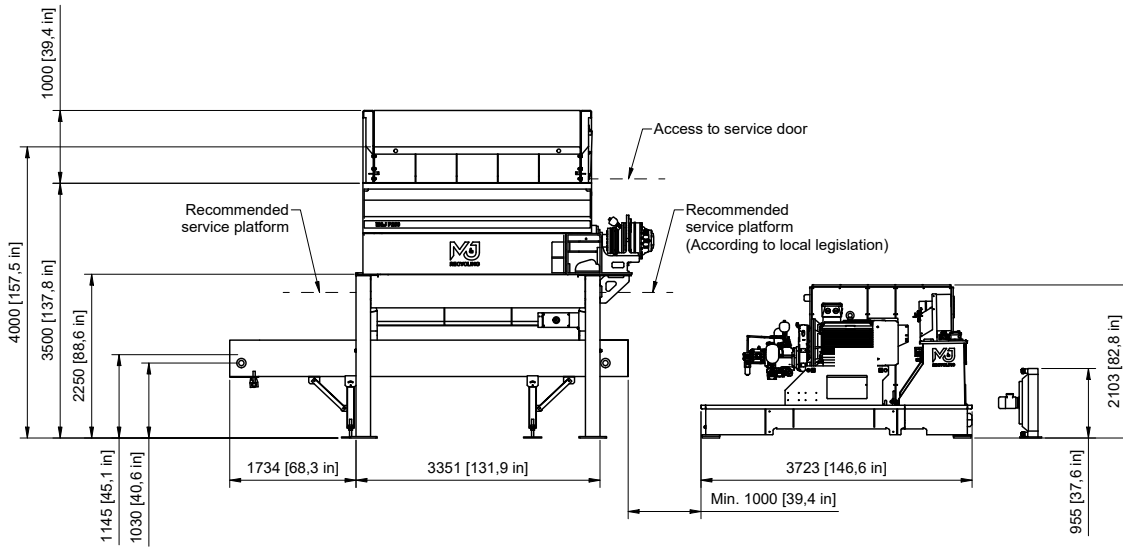



### Version with hydraulic drive

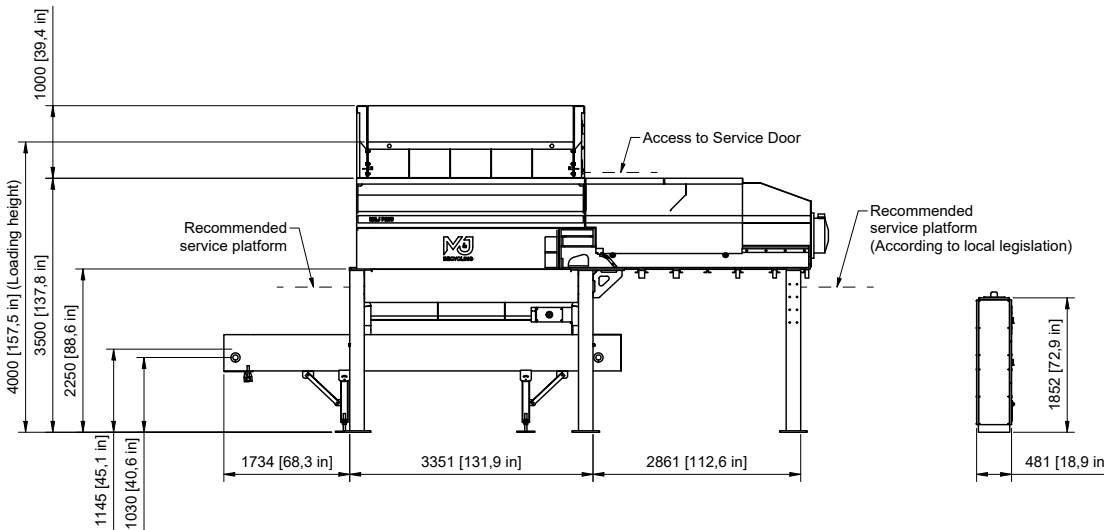

### Version with electric drive

Specification		Hydraulic	Electric
Overall dimensions shredder with standard hopper (LxWxH)	inch	233.0 x 99.6 x 177.2	324.5 x 99.6 x 177.2
Standard colour	RAL	7011, 9002	7011, 9002
Loading height without standard hopper	inch	157.5	157.5
Cutting area	inch	97.4 x 78.7	97.4 x 78.7
<b>Power pack</b>			
Electric motor	horse-power	2 x 177	2 x 150
Electric control unit		PLC	PLC
Drive principle		Double Hydrostatic Transmission	Double Direct Eletrical

# M&J P250



Ninja star



Dragon sword



Classic



Tomahawk



Butterfly



Tachi



Samurai



Version with hydraulic drive



Version with E-drive

Chassis		
Standard belt conveyer (LxW)	inch	196.9 x 48.2
Discharge heightxwidth	inch	45.1 x 48.2

Cutting Table		
Number of shafts	pcs	2
Rotating speed	rpm	Up to 59
Number of knives	pcs	6, 7, 8, 9, 10, 12
Cutting area (LxW)	inch	97.4 x 78.7
Weight complete cutting table	us ton	15.9 to 17.6

Grain size *		Hydraulic	Electric
6 knives	inch	<18	<18
8 knives	inch	<12	<12
9 knives	inch	<10	<10
10 knives	inch	<8	<8
12 knives	inch	<5	

Capacity per hour **		Hydraulic	Electric
Household waste	us ton	Up to 110	Up to 77
Demolition wood	us ton	Up to 77	Up to 55
Industrial waste	us ton	Up to 38	Up to 33***
Bulky waste	us ton	Up to 55	

\* 90% less than \*\* Depending on loading, grain size and density of the input material \*\*\* Easy to medium industrial waste



FOR MORE INFORMATION, CONTACT  
YOUR LOCAL M&J REPRESENTATIVE,  
OR CONTACT YOUR DEALER DIRECTLY.

[MJRECYCLING.COM](https://www.mjrecycling.com)

M & J | Vejlevej 5 | DK-8700 Horsens | Tel: +45 7626 6400 | [sales@mjrecycling.com](mailto:sales@mjrecycling.com)

The information in this document is provided for guidance only and as is without warranty of any kind, either express or implied, including but not limited to the implied warranties of merchantability, fitness for a particular purpose or non-infringement. Information in this document may include information not appropriate to specific configurations, or information which has not been updated. M&J Recycling has the right to make changes in the document without notice. Not all products or services are available in all countries. In no event shall M&J Recycling be liable for any damages. We reserve the right to make changes and improvements without notice.  
\*M&J P250, US\*. M&J Recycling, May 2022.