

M&J K210

Waste Pre-Shredders from M&J Recycling

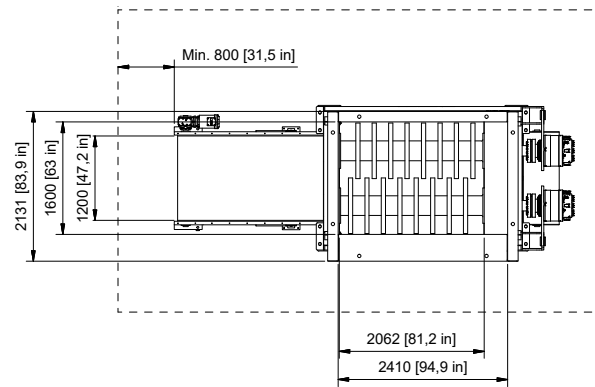

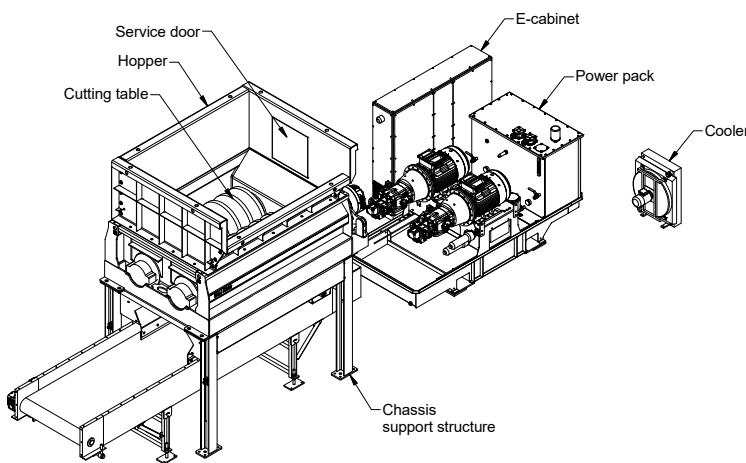
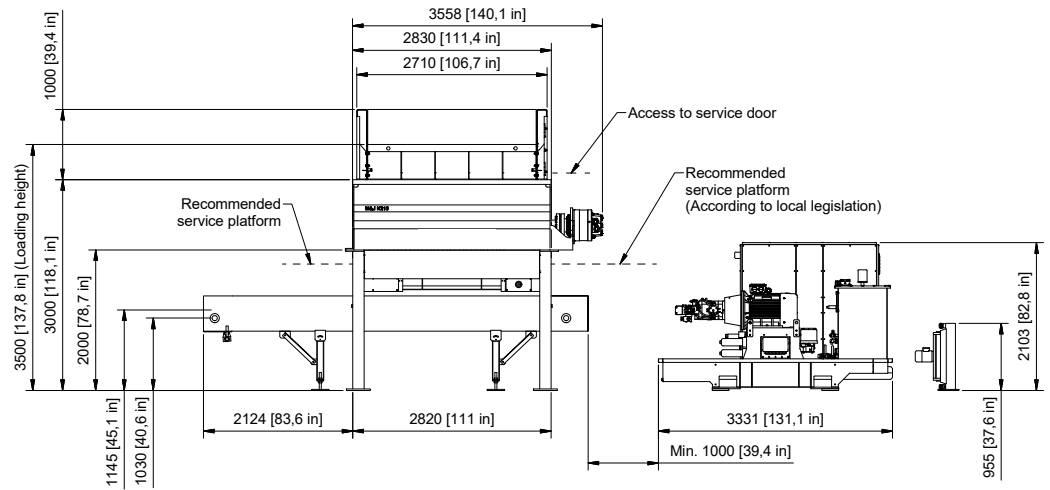

Specification		
Overall dimensions shredder with standard hopper (LxWxH)	inch	386 x 102 x 157,5
Weight (total included standard conveyor)	US ton	11.6 - 12.5
Standard color	RAL	7011, 9002
Loading height with standard hopper	inch	138
Cutting area	inch	81 x 63
Power pack		
Electric motor	Horsepower	2x101 / 2x148 / 2x177
Electric control unit		PLC
Drive principle		Double hydrostatic transmission
Chassis		
Standard belt conveyor (LxW)	inch	197 x 47
Discharge height	inch	45.1
Discharge width	inch	47
Weight (included / exclusive conveyor)	US ton	2.2 / 1.2

M&J K210



Dragon sword



Classic



Tomahawk



Butterfly



Tachi



Samurai



Cutting table 7 knives



Cutting table 11 knives

Cutting Table

Number of shafts		2
Rotating speed	rpm	Up to 62
Number of knives		7 / 8 / 9 / 11
Number of counter knives		14 / 16 / 18 / 22
Cutting area (LxW)	inch	81 x 63
Weight complete cutting table	US ton	8.5 - 9.6

Grain size

7 knives	inch	90% less than 16
8 knives	inch	90% less than 12
9 knives	inch	90% less than 8
11 knives	inch	90% less than 5

Capacity per hour *

Household waste	US ton	Up to 50
Demolition wood	US ton	Up to 44
Industrial waste	US ton	Up to 22
Bulky waste	US ton	Up to 28

* Depending on loading, grain size and density of the input material



FOR MORE INFORMATION, CONTACT
YOUR LOCAL M&J REPRESENTATIVE,
OR CONTACT YOUR DEALER DIRECTLY.

[MJRECYCLING.COM](https://www.mjrecycling.com)

M&J | Vejlevej 5 | DK-8700 Horsens | Tel: +45 7626 6400 | sales@mjrecycling.com

The information in this document is provided for guidance only and as is without warranty of any kind, either express or implied, including but not limited to the implied warranties of merchantability, fitness for a particular purpose or non-infringement. Information in this document may include information not appropriate to specific configurations, or information which has not been updated. M&J Recycling has the right to make changes in the document without notice. Not all products or services are available in all countries. In no event shall M&J Recycling be liable for any damages. We reserve the right to make changes and improvements without notice.
M&J K210 pre shredder, US. M&J Recycling, september 2021.